

UTCA-5503

MicroTCA™ Carrier Hub: Layer 2 GbE switch with MCMC



Features

- Layer 2 GbE switch for up to 12 AdvancedMC™ modules on Common Options Fabric A
- MCH Update channel for Carrier Hub redundancy
- Front panel GbE uplink over RJ-45 or SFP
- Pigeon Point based MCMC with direct or switched 10/100 Management LAN port available on front panel
- IPMB-0 / IPMB-L for complete carrier management
- Built-in expandability for future pluggable enhancements
- Switch Management and Extended Fabric switching
- Customizable clock module and front panel I/O
- Compliant with PICMG MTCA.0 R1.0 specification

Introduction

The Advantech MicroTCA™ Carrier Hub UTCA-5503 combines into a single AdvancedMC Module the control and management infrastructure and the interconnect fabric resources necessary to support up to twelve AdvancedMCs in a MicroTCA shelf:

- A Primary Gigabit Ethernet fabric on Common Options Fabric A
- MicroTCA Carrier Management Controller (MCMC) functions to configure and control the elements

Where redundancy is required, two MCHs permit the creation of highly reliable systems.

Basic Interconnect Fabric, Control and management infrastructure

MicroTCA Carrier Management Controller (MCMC)

The first element on the MCH is the MicroTCA Carrier Management Controller (MCMC). It is the central authority in a MicroTCA Shelf and has the ability to monitor and control the constituent AdvancedMCs. This control function makes use of IPMI Links to each AdvancedMC, as well as presence detect, enable, and Geographic Address signals. When redundant MCHs are installed, failures in the management circuitry on one MCH can be handled by a failover to the other MCH. The MCMC LAN interface is available for optional remote management via the front panel RJ-45 connector or for optional routing to the Base Fabric switch.

E-Keying

Electronic keying (E-Keying) is the responsibility of the Carrier Manager and ensures that all AdvancedMCs and MCHs installed in a Shelf are compatible before they are permitted to power-up and enable their fabric links.

Basic Interconnect Fabric

In its basic configuration, the MCH acts as the Gigabit Ethernet hub of a star network, providing centralized switching and high-speed connectivity to each AdvancedMC. The Gigabit Ethernet Switch on the MCH provides an unmanaged layer 2, non-blocking, low-latency Gigabit Ethernet Switch.

Two MCHs can be used to implement a dual-star topology required for reliability. This is further enhanced by a Gigabit Ethernet Update Channel Port between the two MCHs. A front panel RJ-45 or SFP provides further network expandability with Gigabit Ethernet uplink ports for external interconnects.

This basic configuration provides a solid solution to the most cost sensitive application requirements.

Enhanced Options

Switch Management and Fat Pipes Fabrics

The UTCA-5503 provides extension connectors between PCB1, 2 and 3 for clocks and enhanced processing functions such as Level 2/3 switch management, authentication and encryption; TPM facilities for server/cluster security; or HPI-over-IP remote management. It can also provide PCB3 switching for fat pipes PCI Express, SRIO, GbE or 10 GbE. A PCB2 module can be added for clock distribution and external clock connectivity. The front panel design offers flexibility for clock, I/O and alarm panel requirements.

Clocks and Alarms

An additional PCB2 module can be added to the MCH for enhanced clock distribution and external clock connectivity depending on customer specific requirements. Flexibility has been built into the Front PCB2 module design in order to meet a wide range of current and future Clock, I/O and Alarm panel requirements.

Block Diagram

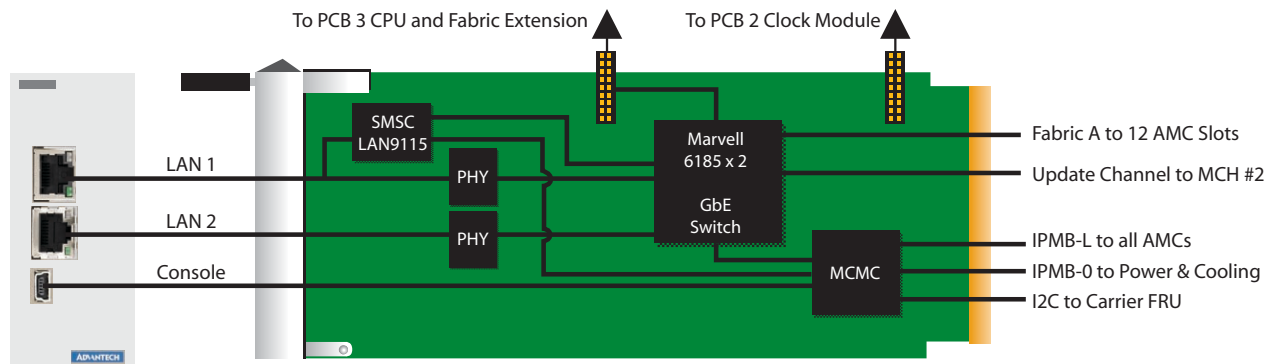

Ordering Information

Model Number	MCMC	LAN1 RJ-45	LAN2 RJ-45	LAN2 SFP	Fabric A GbE Switch	Comments
UTCA-5503-0000E	√	√	-	-	-	Management only, no switch
UTCA-5503-1000E	√	√	√	-	√	Management and Switch
UTCA-5503-2000E	√	√	-	√	√	Management and Switch

Expansion Options

Several options are currently under definition and planning for PCB 2 Clock modules, PCB 3 Processing and Switch management as well as Fat Pipes Fabric switching. Please contact your local sales representative for further details.